



RAMI, Inc.
Grand Haven, MI 49417
(616) 842-9450
www.rami.com

AV-402 ELT Antenna
Operating Frequencies: 121.5, 243, 406 MHz
(Incomplete System)

Installation Instructions

- 1.) Locate position on top of aircraft to mount antenna. Typically mounted aft of passenger/ baggage area and forward of vertical stabilizer.
- 2.) Using the template provided, drill four mounting holes and two holes for the connectors.
Note: Be sure to mount correctly using the front and rear noted on the template.
- 3.) Mount the antenna by placing the rubber pad provided between the antenna base and aircraft skin and the back-up plate provided inside the aircraft. Insert hardware provided as shown below and tighten all mounting screws securely. Good electrical contact is achieved by means of the countersunk washers biting through the painted surface under the mounting screw heads.

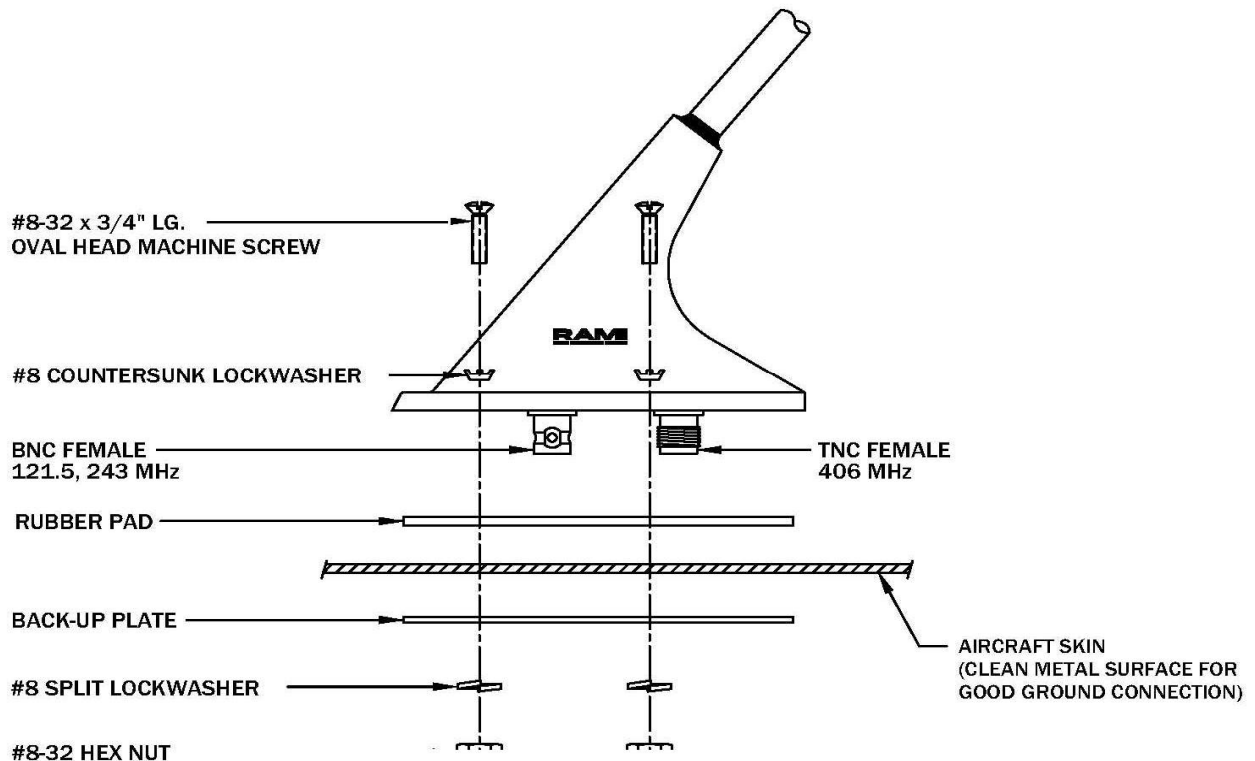

The conditions and tests for TSO approval of this article are minimum performance standards. Those installing this article, on or in a specific type or class of aircraft, must determine that the aircraft installation conditions are within the TSO standards. TSO articles must have separate approval for installation in an aircraft. The article may be installed only according to 14 CFR part 43 or the applicable airworthiness requirements.