

PRODUCT DESCRIPTION

Part Number	RAV30512
NSN	Not Assigned
Market	Military-Air

The RAV30512 is a broadband airborne communications antenna designed for airspeeds less than Mach 1. The antenna housing is a fiberglass epoxy design to withstand the exposure to sand and dust particles of desert areas. The antenna is foam filled to reduce the effects of extreme temperature changes, extreme humidity and excessive shock and vibration. It is mechanically and environmentally qualified to MIL-A-55680 (AT-1108) and has continuous operation altitudes of up to 50,000 feet and temperatures between -65° F and 131° F. It can also withstand the impact shock of 30g and the steady-state acceleration of 6g. This antenna has the same mounting pattern and footprint as the AT-1108/ARC for easy interchangeability if needed. A conductive mounting gasket is supplied with this product.

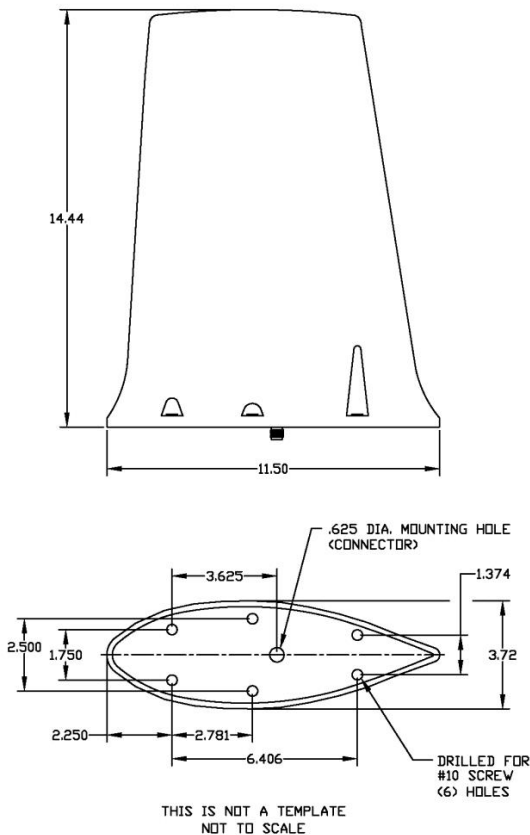

PRODUCT SPECIFICATIONS

Application	Airborne Communications	
Frequency	30-512 MHz	
Impedance	50 Ohms Nominal	
VSWR	3.5:1 Max.	
Polarization	Vertical	
Pattern	Omni-Directional	
RF Power Handling	50 Watts CW	
Gain	-20 dBi @ 30 MHz to 0 dBi @ 300 MHz	
Connector	"TNC" Female	
Weight	3.5 Lbs	
Available Colors	P/N: RAV30512B	CARC Black
	P/N: RAV30512G	CARC Green
	P/N: RAV30512W	White
	P/N: RAV30512T	CARC Tan
	P/N: RAV30512GY	CARC Gray